

F16 DATABASE

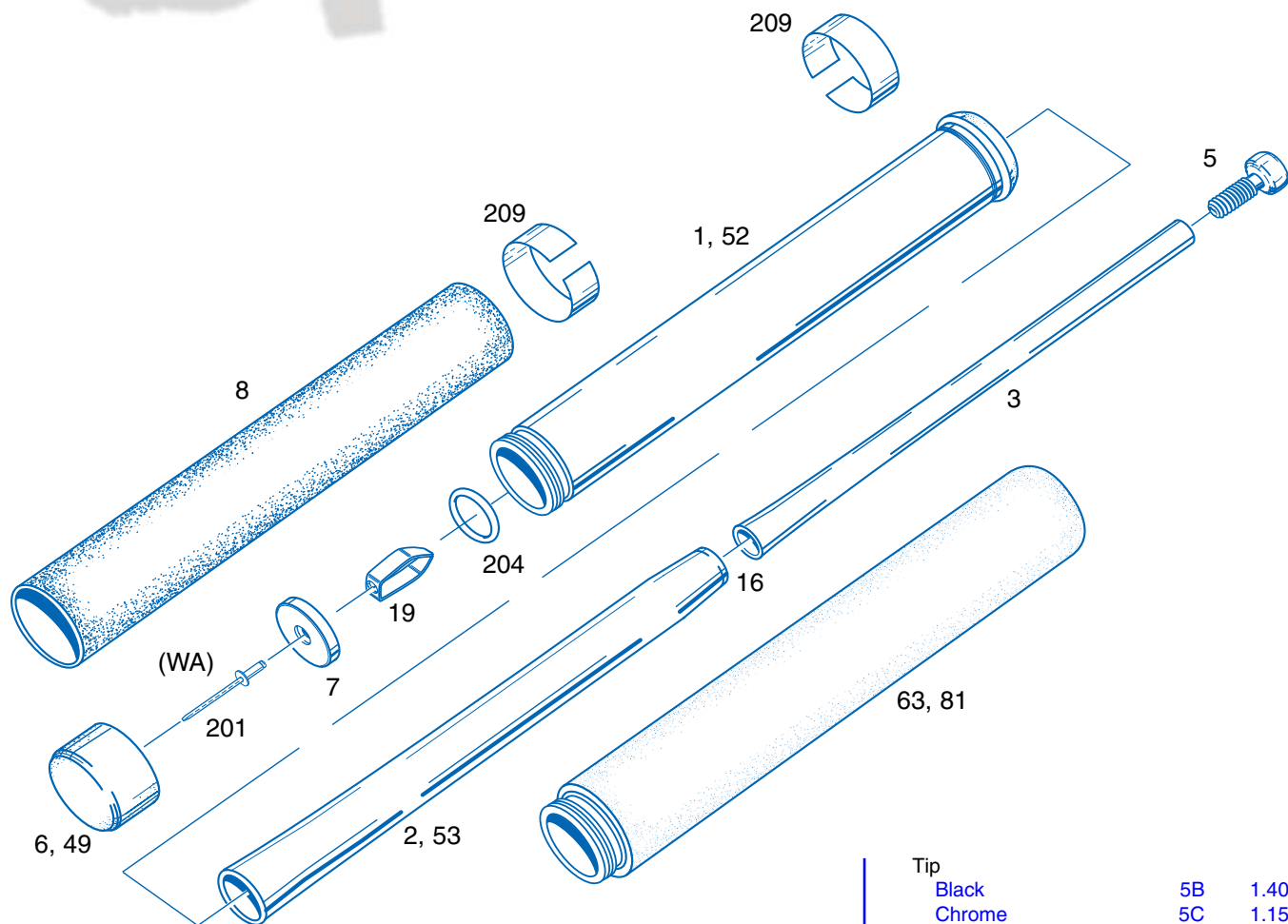

Handle		
Black	1	21.15
Electroless	1E	21.45
Airweight (Aluminum)	52	21.15
Federal	63	17.80
DuraTec (Aluminum)	81	16.75
Middle Tube		
Black	2B	9.25
Chrome	2C	8.05
Electroless	2E	9.50
Gold (Presentation)	2G	15.50
Airweight	53	17.45
End Tube		
Black	3B	10.25
Chrome	3C	9.05
Electroless	3E	10.20
Gold (Presentation)	3G	16.00

Tip		
Black	5B	1.40
Chrome	5C	1.15
Electroless	5E	.95
Gold (Presentation)	5G	12.45
Shaft Assembly*		
Airweight	16A	29.10
Black	16B	20.90
Chrome	16C	18.25
Electroless	16E	20.65
Gold (Presentation)	16G	43.95
Cap		
Black	6	2.30
Electroless	6E	1.95
Airweight	49	2.95
Retaining Clip Assembly** (WA)		
Washer	7	1.10
Retaining Clip	19	.25
Rivet	201	.15
Grip	8	1.60
O-Ring	204	.05
Tape	209	5.00/roll

* Shaft Assembly consists of the Middle Tube, End Tube and Tip
 ** Retaining Clip Assembly consists of the Washer, Retaining Clip and Rivet